

OWNER'S MANUAL

All Weather Day-Night Camera Series



PARTS LIST

This product has been carefully manufactured, tested, inspected and packaged. Please inspect the packaging carefully to ensure you have received all the necessary parts and accessories listed. If any parts are missing or damaged, contact **VideoComm Technologies**, Customer Service or your re-seller immediately.

PARTS	CX-480SR40	CX-520SR100
1 X All Weather Camera with Sun-Hood	X	X
1 X Universal Mounting Bracket	X	X
1 X 12 VDC 500mA Power Supply – # PS-1250	X	-
1 X 12 VDC 1.25 Amp Power Supply – # PS-121A	-	X
1 x Allen-Key	X	-
Operating Instructions	X	X

VideoComm Technologies
Customer Service

www.VideoTransmitters.com

Bus (905)-339-0366

US Toll Free 888-379-2666

Fax (905)-339-1776

E-mail- info@VideoTransmitters.com

Monday - Friday 8:30am- 5:30pm

Eastern Standard Time

INSTALLATION



Power Connection

Only use the power supply included with this camera to ensure proper voltage and amperage.

DO NOT share the power supply with any other device.

CX-480SR40 - 12 VDC Rated @ 500Ma = Model # PS-1250

CX-520SR100 – 12 VDC Rated @ 1.25Amp = Model # PS-121A

Camera Hood Adjustment

Both camera models have a sun-shield to protect the camera face from the elements of weather, or direct sunlight flaring into the camera lens. Slide the shield forward or backward to achieve the desired effect.

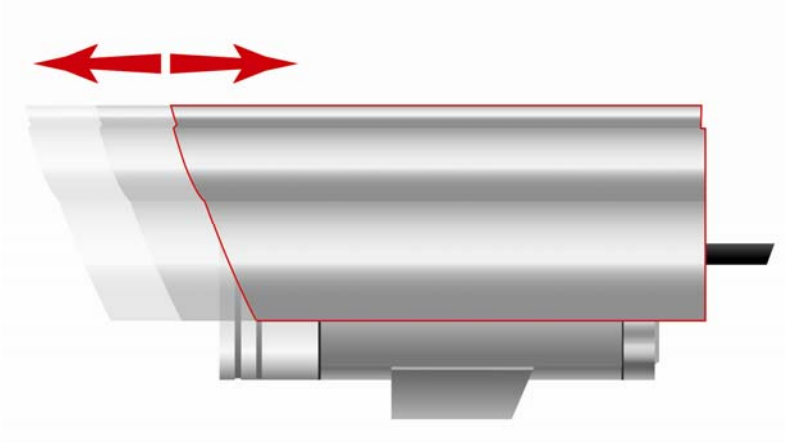

Universal Mounting Bracket Overview

Connection

Both camera models have the ability to mount in almost any scenario – including wall / ceiling / desktop mounting. We suggest using proper counter-sink plugs when mounting the bracket to any surface and ensure proper support. Once the universal bracket is mounted, almost any camera angle can be achieved.

Model # CX-480SR40 Mounting Scenarios

Camera mounting bracket can be positioned for various angles using double jointed mount.

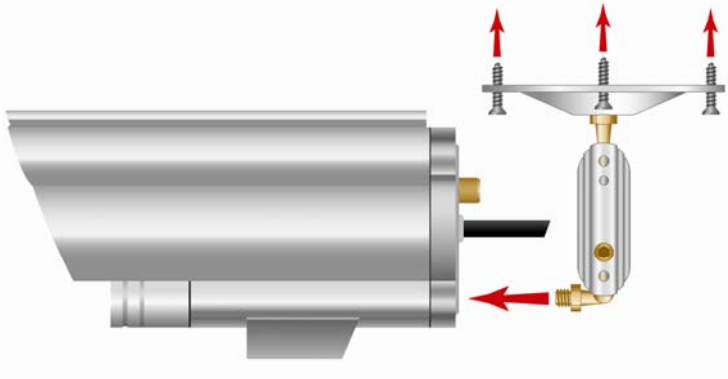

Ceiling Mount Scenario

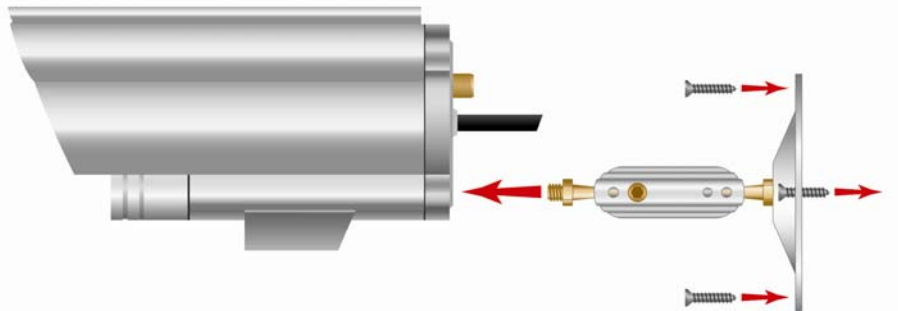
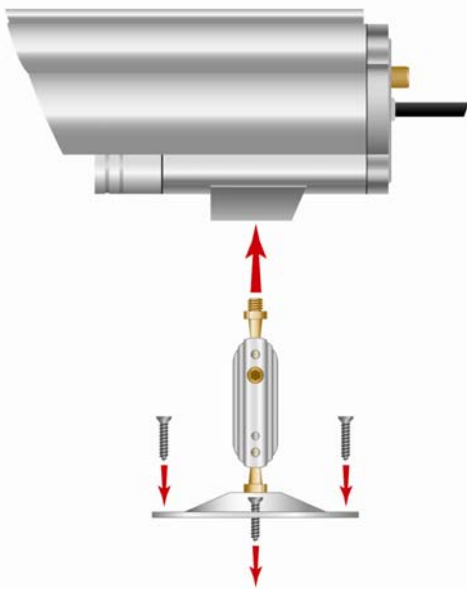

Wall Mount Scenario

Desk Top Mount Scenario

Model # CX-520SR100 Mounting Scenarios

Camera mounting bracket can be positioned for various viewing angles with special pivot and tilt joints.

Under-View of Mounting bracket showing Pivoting head mechanism

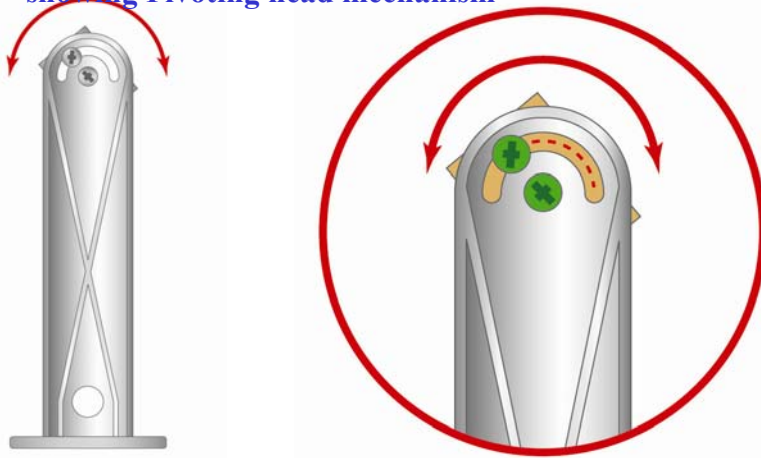

Side-View of Mounting bracket showing Tilting head mechanism

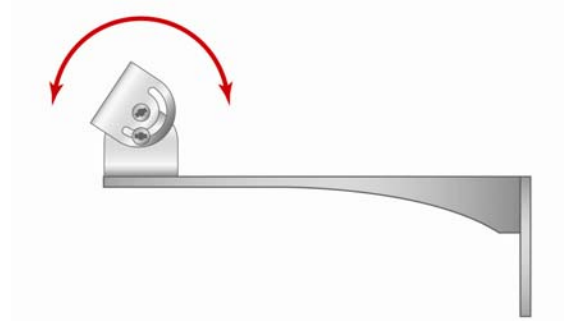

Ceiling Mount Scenario

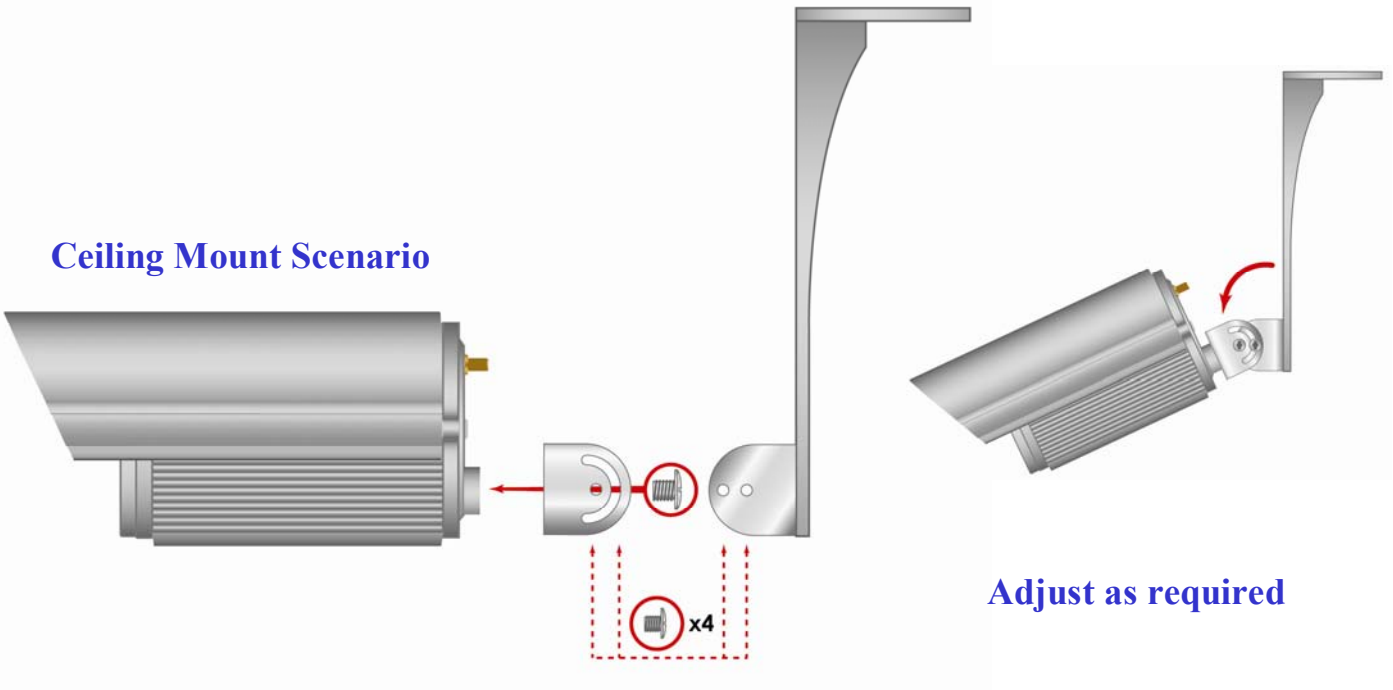

Wall Mount Scenario

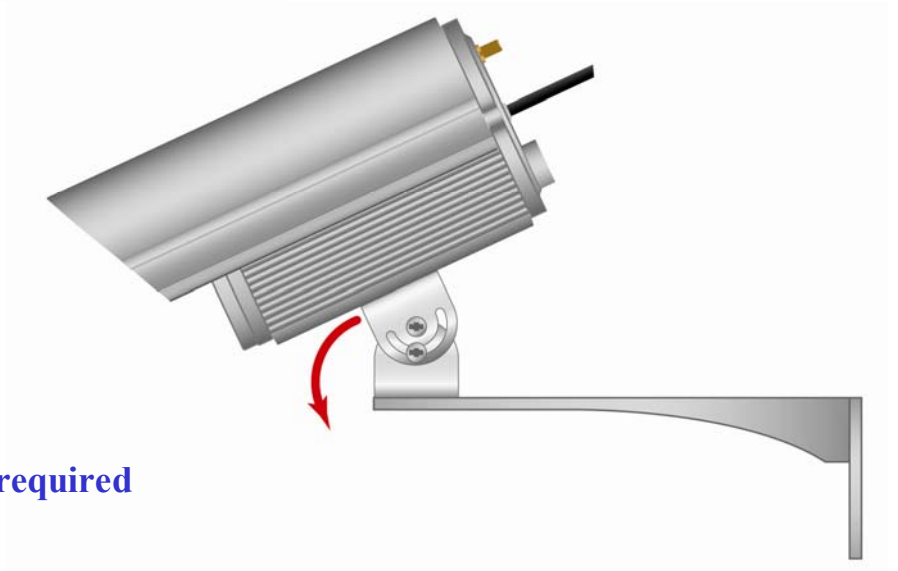
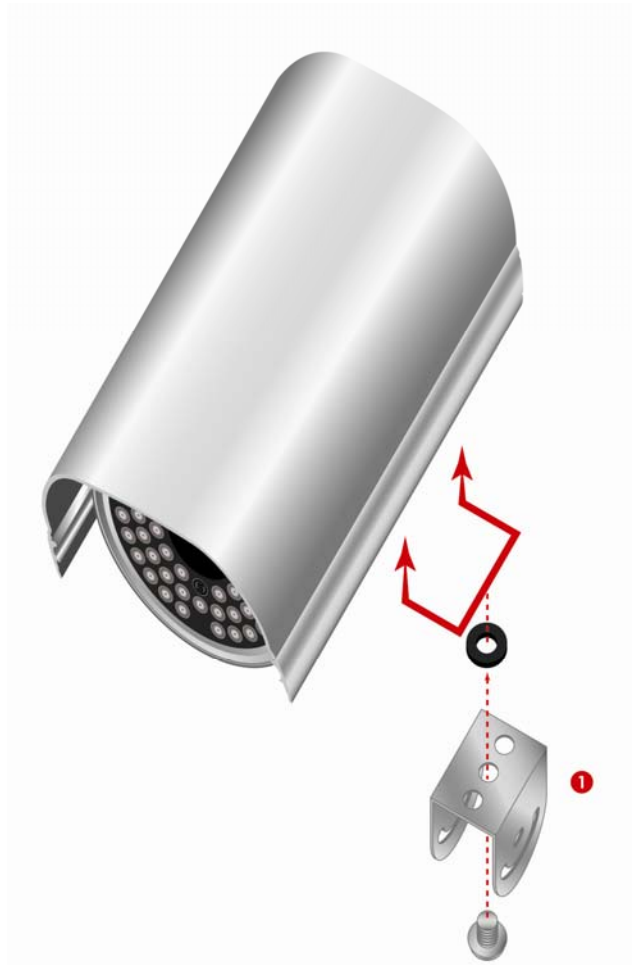
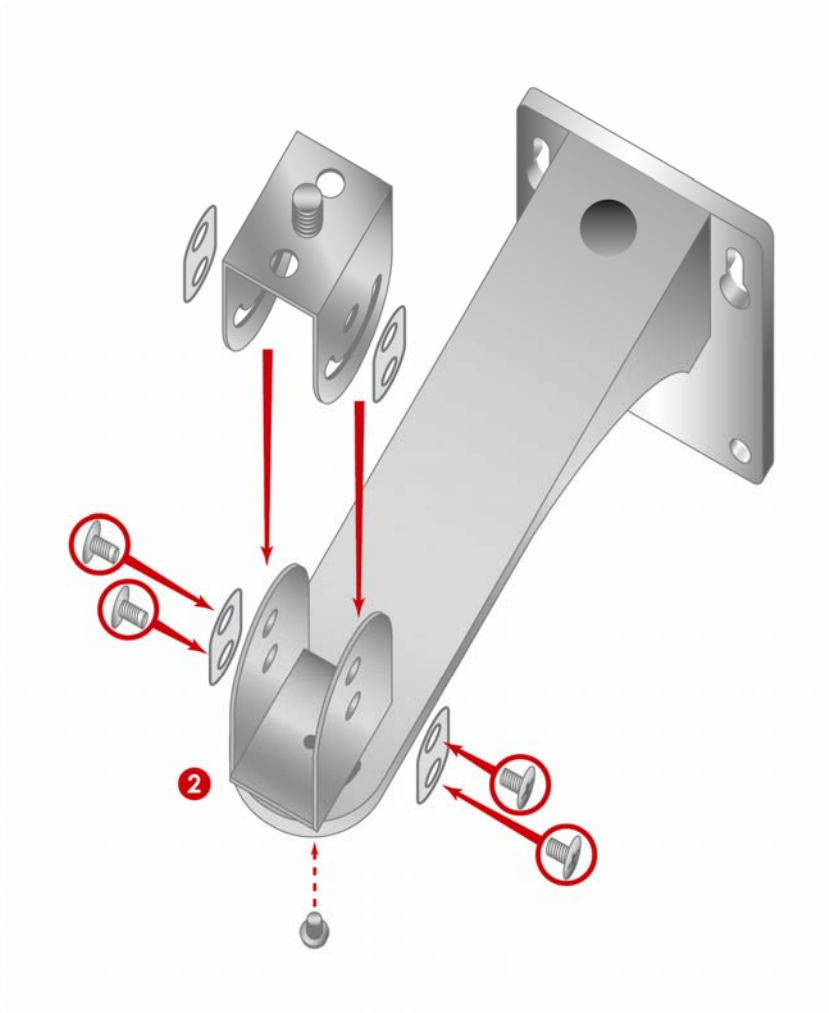

Adjust as required

WARRANTY INFORMATION/ TERMS & CONDITIONS

VideoComm Technologies, herein referred to as "VCT."

LIMITED WARRANTY

VCT hereby warrants, subject to the conditions here in below, that should this product become defective by reason of improper workmanship or material defect during the specified warranty period, VCT will repair the same, effecting all necessary parts without charge for either parts or labor, or replace the unit at VCT option.

Labor: ONE (1) Year from the date of original purchase from authorized Re-seller. TWO (2) Years for Antennas only.

Parts: ONE (1) Year from the date of original purchase from authorized Re-seller. TWO (2) Years for Antennas only.

Void Warranty

Purchaser warranty will be void and purchaser waves any rights to make warranty claim if product has been opened, altered or modified, repaired or serviced by anyone, other than the service facilities authorized by VCT to render such services. Further, the seal/serial number on the unit must not have been altered or removed. The unit must not have been subject to accident, misuse, abuse or operated contrary to the instructions provided. The opinion of VCT with respect to this matter shall be final. This warranty does not include and is not extended to broken and damaged accessories, batteries and exposed antennas and to parts wearing out due to normal wear and tear.

Proper Delivery:

Returned products will not be accepted for warranty repair unless accompanied with a valid Return Merchandise Authorization (RMA) number issued by VCT. RMA numbers issued by VCT are valid for 15 days. Shipments received after 15 days will be refused. The unit must be shipped, freight prepaid or delivered to the VCT Service facility, in either its original package or similar package, affording an equal degree of protection and with instructions indicating the location within Canada or the United States to which the unit will be returned. The repaired unit will be returned to the customer freight prepaid unless the warranty claim is deemed void or invalid. All accessories included with the unit must be listed individually on the packing slip for the shipping documentation. VCT will not accept any liability, for loss or damage to such accessories if they are not listed.

Proof of Purchase Date:

This warranty applies and commences to VCT products, from the original date of purchase from an Authorized Re-seller. Proof of purchase (i.e.: photocopy of invoice), must be included with product when submitting for warranty repair.

Warranty Limitations:

This warranty does not cover maintenance or check-ups, if required. This warranty gives you specific legal rights and you may also have other rights, which vary from state/province to state/province. Some states/provinces do not allow the exclusion or limitation of incidental or consequential damages or limitations on how long an implied warranty lasts, therefore the above exclusions or limitations may not apply to you. VCT is not responsible or liable for indirect, special, incidental or consequential damages arising out of or in connection with, the use or performance of the product or other damages with respect to loss of property, loss of revenues or profit, or cost of removal, installation or reinstallation.

PRODUCT RETURNS

30 Day Product Return Policy ** If you are not satisfied with a product, you may return it to VCT within 30 days from original date of shipment within the following conditions:

- ◆ Original shipping charges are not refundable unless deemed that VCT shipped incorrect item(s), incorrect quantity (ies) or original manufacturer's defective product (subject to VCT validation).
- ◆ Returned products will not be accepted unless accompanied with a valid Return Merchandise Authorization number (RMA).
- ◆ RMA numbers issued by VCT are valid for 15 days. Shipments received after 15 days will be refused.
- ◆ Returns must include a copy of original invoice, the completed VCT packing slip, and a detailed statement of reason for return.
- ◆ Customer is responsible for all freight charges, duties and taxes, if applicable. Product must be properly packaged and shipped, prepaid to VCT in its original packaging, or similar packaging that offers an equal degree of protection. VCT will charge the full replacement cost for any missing components or parts. VCT is not responsible for lost or damaged merchandise. We strongly recommend insuring products for return shipping.
- ◆ Return claims are void if manufacturer's seal is broken and/or products are altered or modified, subjected to an accident, improper handling, improper installation, misuse and abuse or operated contrary to the operating instructions. Products returned that are not in "re-saleable" condition will be returned to customer at their expense.
- ◆ Discontinued items, special or custom-made equipment items (items not carried as stock even though they may appear on price lists) may not be returned. Returned products will be evaluated at the original purchase price and not at any subsequent price increase or decrease.

** Subject to the conditions stated above, the following re-stocking fees will apply to products returned for credit/refund.

VCT reserves the right to determine the validity of the product returned and / or refuse to accept product for credit.

0 % Re-Stocking Fee (less original shipping charges): If product is returned within 30 days from original VCT ship date.

25% Re-Stocking Fee (less original shipping charges): If product is returned within 60 days from original VCT ship date.

50% Re-Stocking Fee (less original shipping charges): If product is returned within 90 days from original VCT ship date.

100% Re-Stocking Fee (0% credit) : If product is returned after 90 days from original VCT ship date.

DISCLAIMER

In no event will VCT or any of its affiliates be liable for any indirect, special, punitive, consequential liability, or incidental damages upon any basis of liability whatsoever even if advised of the possibility of such damages. In addition, VCT does not take any responsibility or assume any liability for the wiring, installation or placement of the equipment Customer purchases, or for the activities of any other individual or entity such as Customer's Company, those who prepare the specifications or any local Authorities who inspect or approve Customer's installation.